



UTILITY GRAPPLE FORK



FEATURES:

- Designed for skid steers and loaders
- Ideal for fast hay, manure & light debris movement
- Durable construction for long life
- Adjustable bolt on grapple tines
- Heavy duty 3" bore single ram provides excellent clench force to secure load
- All steel construction laser cut for accuracy
- Open frame for excellent visibility
- Available in widths from 60" to 74"
- 1-1/2" solid square bolt on fork tines
- 3/8" plate grapple tines
- All pivot pins are serviceable
- Durable black paint finish

OPEN VIEW

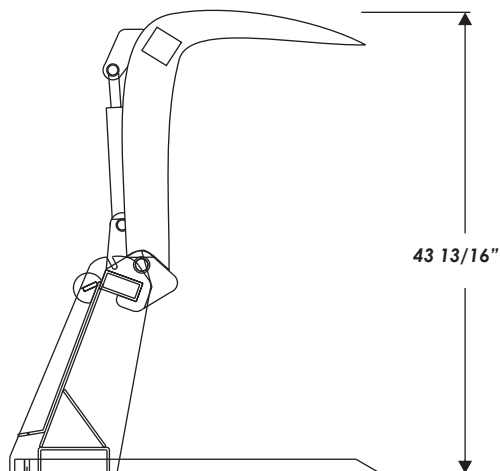

SPECIFICATIONS:

Model #	Fork Width	# of Fork Tines	# of Grapple Tines	Approx. Weight
UGF 60	59-13/16"	9	4	675 lbs.
UGF 66	66-13/16"	10	4	773 lbs.
UGF 74	73-13/16"	11	4	798 lbs.



* The above numbers reflect the weight of the implement. Please refer to your owners manual of your skid steer for lift capacities.

CLOSED VIEW

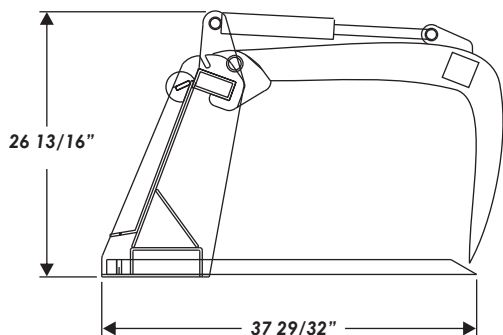

GRIDLOCK
Manufacturing Technique

This product features our Grid Lock manufacturing technique that allows for increased strength with less overall weight.



All products are subject to change without notice or liability.

Toll Free: 1-877-947-2882
www.conterraindustries.com

Box 59, Rockyford, Alberta Canada T0J 2R0
Ph: (403) 947-2882 Fax: (403) 947-2892

D3