

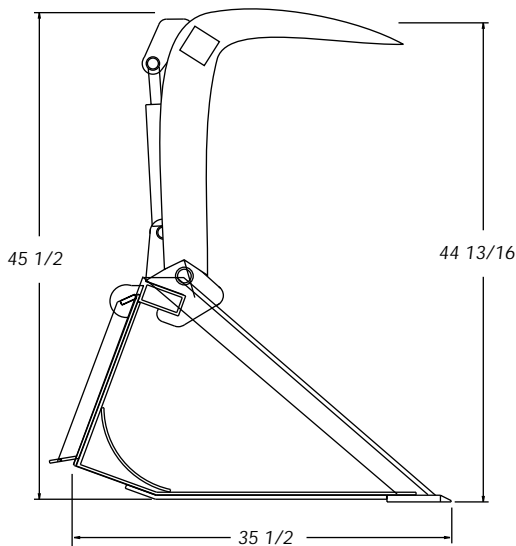

UTILITY GRAPPLE BUCKET



OPEN VIEW



CLOSED VIEW

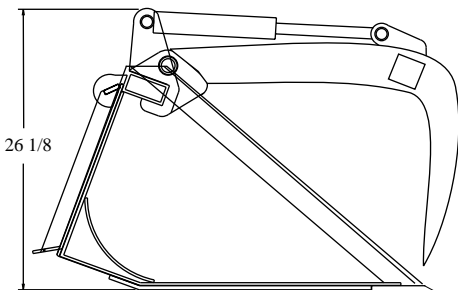

All products are subject to change without notice or liability.

FEATURES:

- Designed for skid steers and loaders
- Ideal for fast hay, manure & light debris movement
- Durable construction for long life
- Heavy duty 3" bore single ram provides excellent clench force to secure load
- Available with bolt on cutting edge or teeth
- All steel construction laser cut for accuracy
- Open frame for excellent visibility
- Available in widths from 62 to 74"
- 1/4" plate bucket sides
- 1/4" plate bottom and back wrapper
- 3/16" plate rolled bucket back
- 1/2" x 2-1/2" bucket wear plates
- 3/8" plate grapple tines
- All pivot pins are serviceable
- Protective ram guard
- Includes 5/8" x 8" bolt on cutting edge or large style pin on teeth
- Durable black paint finish

SPECIFICATIONS:



Model #	Fork Width	# Fork Tines	# Grapple Tines	Approx. Weight
UGB-BE 62	62-1/4"	9	4	680 lbs.
UGB-BE 68	68-1/4"	10	4	700 lbs.
UGB-BE 74	73-3/8"	11	4	715 lbs.

* The above numbers reflect the weight of the implement. Please refer to your owners manual of your skid steer for lift capacities.



This product features our Grid Lock manufacturing technique that allows for increased strength with less overall weight.

Toll Free: 1-877-947-2882
www.conterraindustries.com

Box 59, Rockyford, Alberta Canada T0J 2R0
 Ph: (403) 947-2882 Fax: (403) 947-2892

D2