



# UTILITY BUCKET



## FEATURES:

- Universal attachment plate fits most skidsteers
- Excellent for handling higher volumes of material
- Formed bucket back design for added strength
- 2" x 4" square tube top bar is sloped for better cutting edge visibility
- 1/2" x 2-1/2" bucket bottom wear skids
- 3/8" x 2-1/2" bucket side edges
- 1/4" plate bucket sides
- 1/4" plate bottom and back wrapper
- 5/8" x 6" base cutting edge
- 5/8" x 8" double bevel bolt on cutting edge
- Durable Black paint finish



## OPTIONS:

- Material cage available for added safety

## SPECIFICATIONS:

Model #	Bucket Width	Struck Capacity	Weight
UB-BE 68	68-1/4"	22.4 ft <sup>3</sup>	620 lbs
UB-BE 74	73-3/8"	23.6 ft <sup>3</sup>	640 lbs
UB-BE 80	80-3/16"	24.7 ft <sup>3</sup>	680 lbs
UB-BE 86	85-1/2"	25.8 ft <sup>3</sup>	740 lbs.
UB-BE 98	97-1/2"	29.4 ft <sup>3</sup>	790 lbs.

\* The above numbers reflect the capacity of the attachment, and may be in excess of the lift capacity of some skid steers. Please see your owners manual for specific lift capacities.

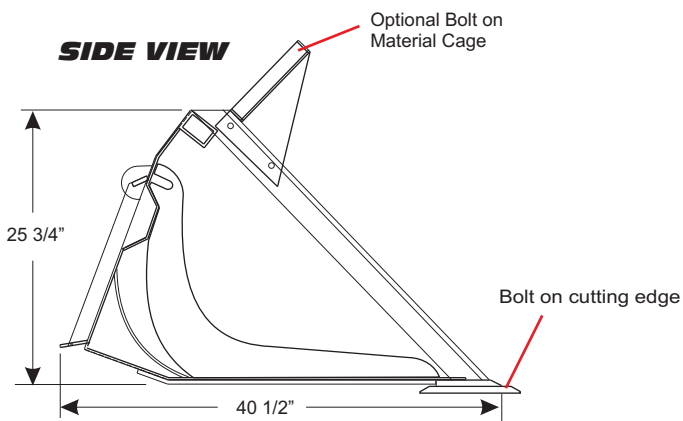

*This product features our Grid Lock manufacturing technique that allows for increased strength with less overall weight.*



All products are subject to change without notice or liability.

**Toll Free: 1-877-947-2882**  
**www.conterraindustries.com**

Box 59, Rockyford, Alberta Canada T0J 2R0  
 Ph: (403) 947-2882 Fax: (403) 947-2892

C4