



UNIVERSAL MOUNT PLATE



FEATURES:

- Our weld on universal plate adapts to most major brands of late model skid steers
- ASV RC 30 mounts and Bobcat 463 mounts are also available
- Heavy duty 3/8" plate is used for the top lip and the lower pin plate to ensure a strong tight fit
- Grid lock manufacturing makes this plate the best built in the business
- The plate comes assembled ready to be welded on to what ever attachment you desire
- Key components are laser cut to ensure accuracy
- All plates come unpainted

SIDE VIEW

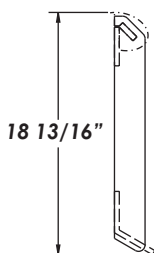

FRONT VIEW

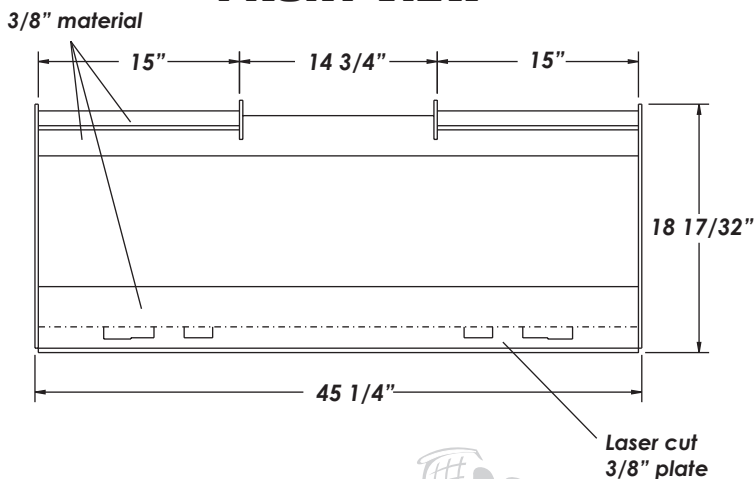

This product features our Grid Lock manufacturing technique that allows for increased strength with less overall weight.



SPECIFICATIONS:

Part #	Model #	Width	Height	Weight
103600	UQA 01	45.25"	18.8"	60 lbs

* The above numbers reflect the approximate weight of the attachment, and may be in excess of the lift capacity of some skid steers. Please check your owners manual for specific lift capacities.



All products are subject to change without notice or liability.

Toll Free: 1-877-947-2882
www.conterraindustries.com

Box 59, Rockyford, Alberta Canada T0J 2R0
 Ph: (403) 947-2882 Fax: (403) 947-2892

H1

PRINTED IN CANADA
 PRINTED IN CANADA