



ROUND BALE GRAPPLE

NEW PRODUCT



FEATURES:

- Designed for skid steers and loaders
- Great for easy, safe round bale handling
- Heavy duty 4" x 4" square tube construction for long life
- Powered by one 3" hydraulic rams
- Bale tines are laser cut form 1/2" steel and then fabricated in a half diamond shape
- Grapple tine are laser cut out of 5/8" plate steel
- Grapple opens to 66" and closes down to 39" above the tines
- 1-1/4" main pivot pins and 1" ram pins,
- All pivot points are servicable
- Durable black paint finish



SPECIFICATIONS:

Model #	Open Height	Closed Height	# of Bale Tines	Approx. Weight
RBG 2000	66"	39"	2	350 lbs.

CLOSED VIEW

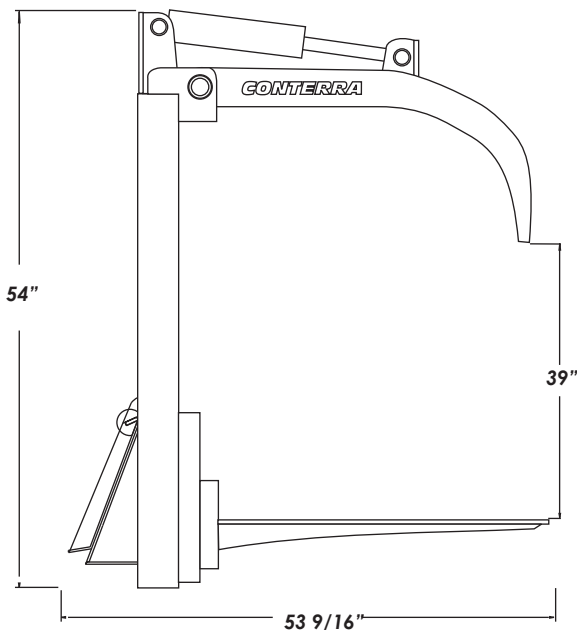

* The above numbers reflect the weight of the implement. Please refer to your owners manual of your skid steer for lift capacities.



GRID LOCK
Manufacturing Technique

This product features our Grid Lock manufacturing technique that allows for increased strength with less overall weight.



All products are subject to change without notice or liability.

Toll Free: 1-877-947-2882
www.conterraindustries.com

Box 59, Rockyford, Alberta Canada T0J 2R0
Ph: (403) 947-2882 Fax: (403) 947-2892

D16