



# ROCK BUCKET



## FEATURES:

- Built for skid steers and loaders
- Ideal for quick and efficient rock and debris removal, transportation and dumping
- Heavy duty 1/4" plate bucket sides with 3/8" x 2-1/2" side cutter bars
- 3/8" plate laser cut rake tines on 3" centers
- 2" x 4" square tube top bucket bar for added strength
- 5/8" x 6" base cutting edge with weld on flush mount adapters and pin on dirt teeth
- Heavy duty construction for long lasting performance
- Durable black paint finish



## OPTIONS:

\*Bucket available with bolt on edge (BE) or large digging teeth ((LT) (example:.. RB-BE 62 or RB-LT 62)

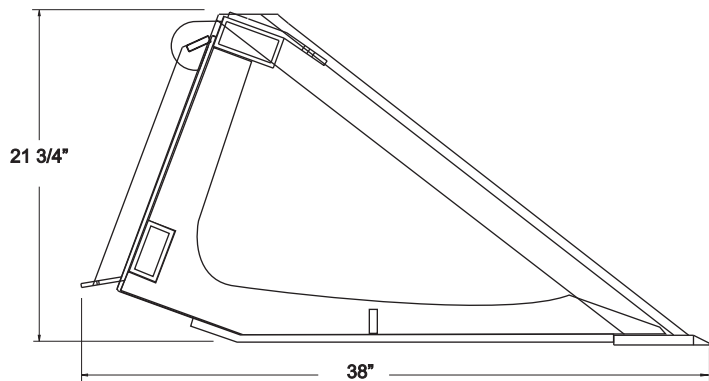

*This product features our Grid Lock manufacturing technique that allows for increased strength with less overall weight.*

## SPECIFICATIONS:

Model #	Bucket Width	Weight
RB 62	62 1/4"	568 lbs
RB 68	68 1/4"	588 lbs.
RB 74	72 1/4"	647 lbs.
RB 80	80 7/8"	694 lbs.
RB 86	85 1/2"	741 lbs.

\* The above numbers reflect the capacity of the attachment, and may be in excess of the lift capacity of some skid steers or loaders. Please see your owners manual for specific operating and lift capacities.



All products are subject to change without notice or liability.

**Toll Free: 1-877-947-2882**  
**www.conterraindustries.com**

Box 59, Rockyford, Alberta Canada T0J 2R0  
 Ph: (403) 947-2882 Fax: (403) 947-2892

C7