



PIPE GRAPPLE

NEW PRODUCT



FEATURES:

- Fits most late model skid steers
- Ideal for safe fast pipe and material handling
- Capable of handling pipe from 2" to 24" diameter
- The scissor action grapple allows tines to manually adjust to handle an array of pipe sizes
- Wide carriage adds extra load stability
- Grapple opens up out of the way so unit can be utilized as a conventional pallet fork.
- 3/16" plate brick back mast for great visibility
- Top and bottom of pallet fork tines are secured by rails
- Tines are easily moved and secured in place with quick latch system
- Tines can be removed
- Heavy duty construction
- Laser cut components ensure superior quality
- Durable paint finish

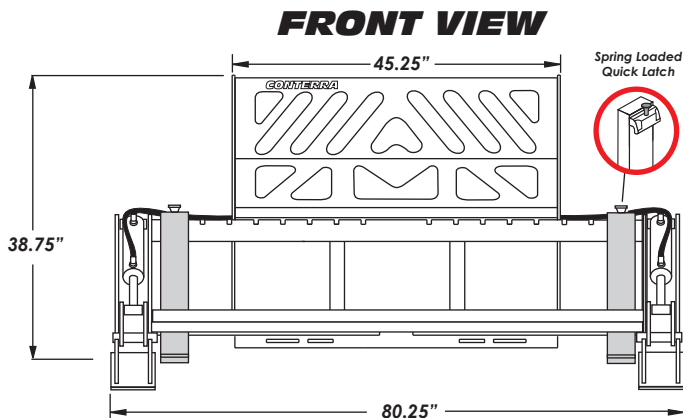
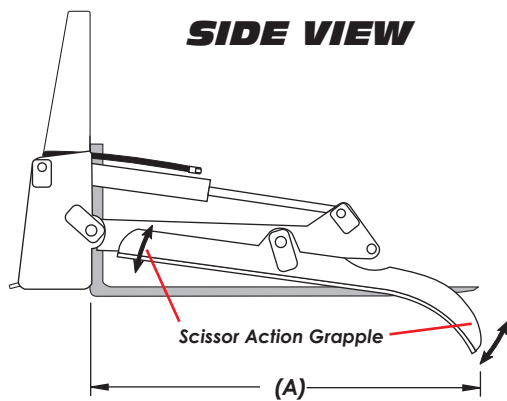

SPECIFICATIONS:

Model #	Frame Width	(A) Tine Length	Weight	Capacity @ 22" load center
PG 5500-48	80.25"	48"	659 lbs	5500 lbs max

* The above numbers reflect the capacity of the attachment, may be in excess of the lift capacity of some skid steers. Please check your owners manual for specific lift capacities.



All products are subject to change without notice or liability.

Toll Free: 1-877-947-2882
www.conterraindustries.com

Box 59, Rockyford, Alberta Canada T0J 2R0
 Ph: (403) 947-2882 Fax: (403) 947-2892

D17

PRINTED IN CANADA