



MINI HOE



FEATURES:

- Mounts easily to any skid steer
- Requires no stabilizer pads
- 3" cylinder for excellent break out force
- Excellent mobility for digging in tight places
- Ideal for digging footings and trenches
- Available in 72" and 84" reach models
- Buckets sizes range from 8" to 24"
- All buckets come with flush mount adapters and crimp on replaceable cutting teeth (optional smooth edge available)
- All pins are serviceable
- 4" x 6" square tube boom arm
- 3/16" plate bucket wrapper
- 1/4" plate bucket sides
- 1/2" x 2 1/2" bucket wear plates
- 5/8" x 6" base cutting edge
- 1-1/4" main pivot pin
- Heavy duty construction
- Durable black paint finish
- Available with optional Thumb and Ripper tooth attachments



SPECIFICATIONS:

Model #	Extension Length (A)	Bucket Width	# of Bucket Teeth	Weight
MH 72-8T	72"	8"	2	240 lbs
MH 72-12T	72"	12"	3	260 lbs
MH 72-16T	72"	16"	4	280 lbs
MH 72-24T	72"	24"	5	300 lbs
MH 84-8T	84"	8"	2	280 lbs
MH 84-12T	84"	12"	3	300 lbs
MH 84-16T	84"	16"	4	320 lbs
MH 84-24T	84"	24"	5	340 lbs

SIDE VIEW

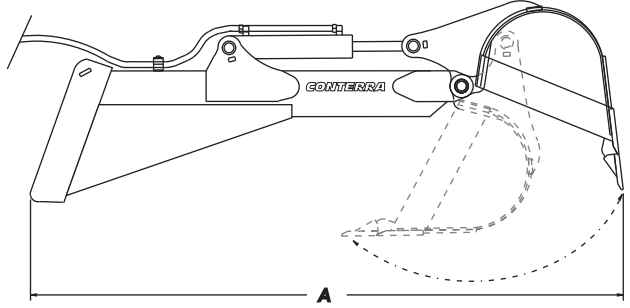

* The above numbers reflect the weight of the attachment, and may be in excess of the lift capacity of some skid steers. Please check your owners manual for specific lift capacities.



This product features our Grid Lock manufacturing technique that allows for increased strength with less overall weight.



All products are subject to change without notice or liability.

Toll Free: 1-877-947-2882
www.conterraindustries.com

Box 59, Rockyford, Alberta Canada T0J 2R0
 Ph: (403) 947-2882 Fax: (403) 947-2892

E3