



MANURE FORK



FEATURES:

- Designed for skid steers and loaders
- Ideal for fast hay, manure & debris movement
- Bolt mounted 1-1/2" x 1-1/2" square solid steel tines (replaceable)
- 1/4" plate back and tine plate
- 3/8" plate bottom
- Available in widths from 62" to 98"
- Durable black paint finish



SPECIFICATIONS:

Model #	Fork Width	# Fork Tines	Approx. Weight
MF 62	62-1/4"	9	605 lbs.
MF 68	68-1/4"	10	713 lbs.
MF 74	73-3/8"	11	768 lbs.
MF 80	80-3/16"	12	793 lbs.
MF 86	85-1/2"	12	805 lbs.
MF 98	97-1/2"	13	833 lbs.

SIDE VIEW

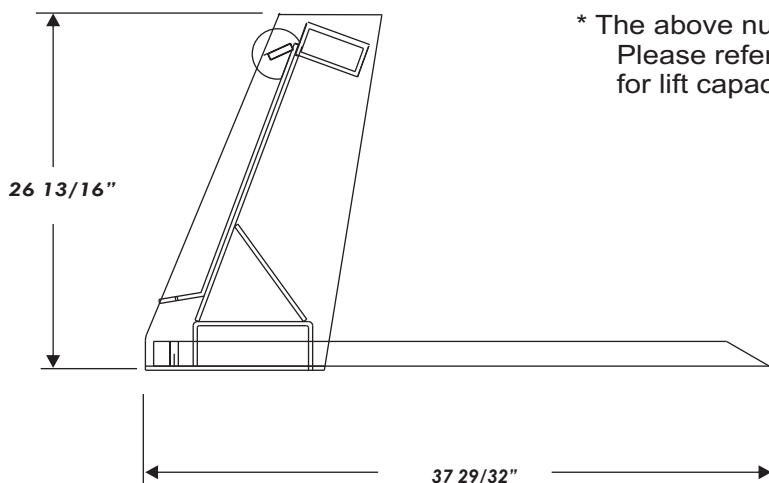

* The above numbers reflect the weight of the implement. Please refer to your owners manual of your skid steer for lift capacities.

GRIDLOCK

Manufacturing Technique

This product features our Grid Lock manufacturing technique that allows for increased strength with less overall weight.



All products are subject to change without notice or liability.

Toll Free: 1-877-947-2882
www.conterraindustries.com

Box 59, Rockyford, Alberta Canada T0J 2R0
 Ph: (403) 947-2882 Fax: (403) 947-2892

D4