



LOG SPLITTER



New model not exactly as shown

FEATURES:

- Fits most late model skid steers
- Allows for fast and easy log splitting for logs up to 24" long
- Powered by 4" cylinder that produces up to 20 tons of force
- The cylinder has a 24" stroke and a maximum hydraulic pressure of 3000 psi
- The unit is operated by a single control lever with an automatic kick off valve that allows both hands to be free to handle split wood and set up new log while ram is retracting
- 30 second cycle time at full load
- Durable construction and black paint finish

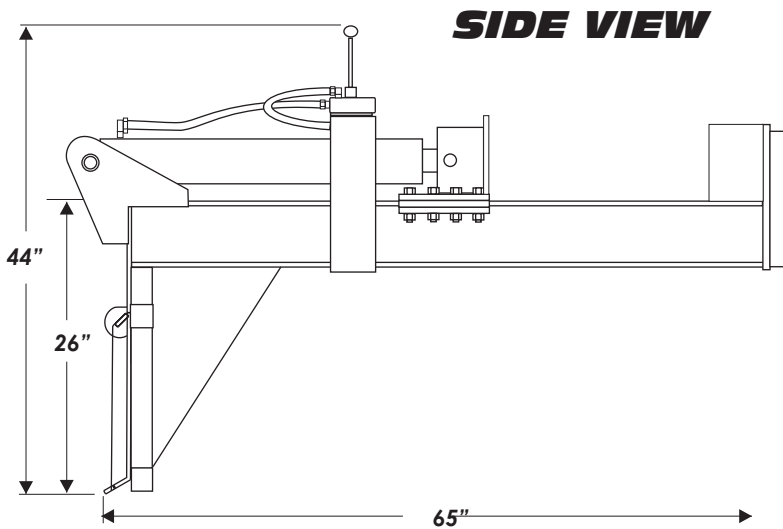

This product features our Grid Lock manufacturing technique that allows for increased strength with less overall weight.

SPECIFICATIONS:

Part #	Model #	Frame Width	Frame Length	Ram Bore	Output Tons	Max Hyd. Pressure	Weight
104700	LS 20	48"	64"	5"	20	3000psi	254 lbs

* The above numbers reflect the capacity of the attachment, and may be in excess of the capacity of some skid steers. Please check your owners manual for specific capacities.



All products are subject to change without notice or liability.

Toll Free: 1-877-947-2882
www.conterraindustries.com

Box 59, Rockyford, Alberta Canada T0J 2R0
 Ph: (403) 947-2882 Fax: (403) 947-2892

F14