



LIFT BOOM



FEATURES:

- Universal mount fits most skid steers
- Allows for easy lifting and transporting of materials
- Design allow for optimal reach when Lift Boom is rolled ahead and increased lift capabilities when Lift Boom is in upright position
- Three models to choose from with reach lengths from 72" to 120"
- Main boom is constructed using 4" x 6" square tube
- Support frame is constructed using 3" x 3" square tube
- Lift shackle mount plate is lazer cut from 1/2" plate
- Heavy duty construction
- Durable black paint finish



SPECIFICATIONS:

Part #	Model #	Overall Reach	Frame Width	Max Load	Weight
104800	LB 72-2000	72"	46.75"	2000lbs	313 lbs
104801	LB 96-2000	96"	46.75"	2000lbs	420 lbs
104802	LB 120-2000	120"	46.75"	2000lbs	480 lbs

* The above numbers reflect the weight of the attachment, and may be in excess of the lift capacity of some skid steers. Please check your owners manual for specific lift capacities.

SIDE VIEWS

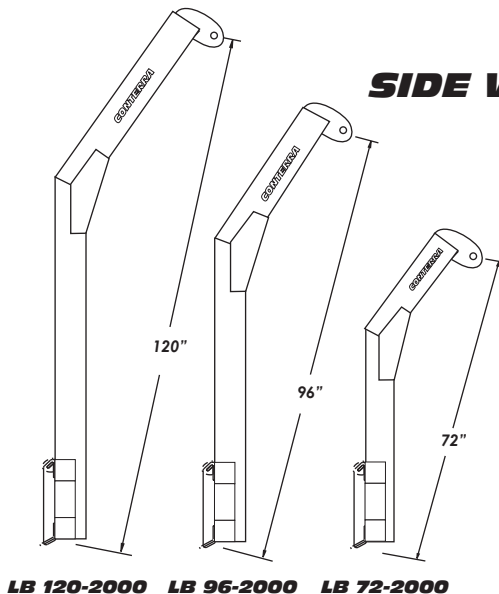

GRID LOCK
Manufacturing Technique

This product features our Grid Lock manufacturing technique that allows for increased strength with less overall weight.



All products are subject to change without notice or liability.

Toll Free: 1-877-947-2882
www.conterraindustries.com

Box 59, Rockyford, Alberta Canada T0J 2R0
Ph: (403) 947-2882 Fax: (403) 947-2892

E13