



HIGH VOLUME BUCKET



FEATURES:

- Universal attachment fits most skid steer
- Ideal for fast efficient movement of material such as grain, fertilizer and vegetables
- 60 degree bucket opening for maximum capacity at full roll back
- Double formed inside curve and bent back design for added bucket strength
- 2 1/2" x 1/2" bottom wear plates
- 1/4" bottom and back wrapper
- 1/4" plate bucket sides
- 2" x 3" square tube top bar
- 5/8" x 6" weld on base cutting edge
- 5/8" x 8" double bevel bolt on cutting edge
- Durable black paint finish



SPECIFICATIONS:

Model #	Width	Struck Capacity	Weight
HVB-BE 68	68-1/4"	29.1 ft ³	655 lbs.
HVB-BE 74	73-3/8"	31.2 ft ³	705 lbs.
HVB-BE 80	80-3/16"	32.6 ft ³	755 lbs.
HVB-BE 86	85-1/2"	34.3 ft ³	785 lbs.
HVB-BE 98	97-1/2"	36.2 ft ³	821 lbs.

SIDE VIEW

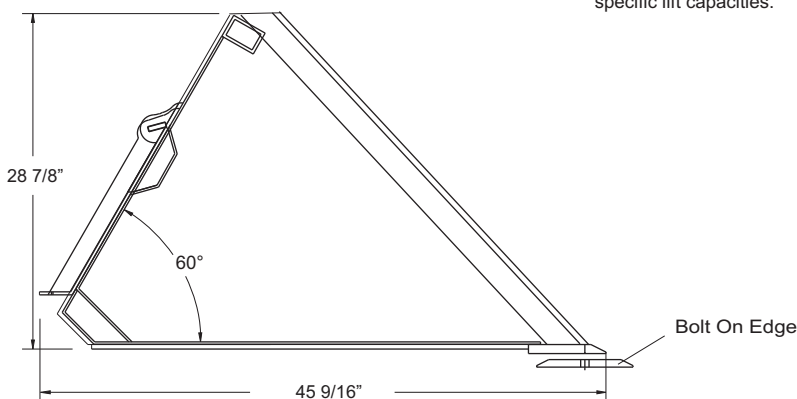

* The above numbers reflect the capacity of the attachment, and may be in excess of the lift capacity of some skid steers and loaders. Please see your owners manual for specific lift capacities.



This product features our Grid Lock manufacturing technique that allows for increased strength with less overall weight.



All products are subject to change without notice or liability.

Toll Free: 1-877-947-2882
www.conterraindustries.com

Box 59, Rockyford, Alberta Canada T0J 2R0
 Ph: (403) 947-2882 Fax: (403) 947-2892

C5