



CEMENT MIXER



FEATURES:

- Built for use on skid steers and loaders with the universal mount
- The Cement Mixer is an ideal attachment for batch mixing, transporting and placing concrete in confined spaces
- Welded steel drum and paddles provide excellent mixing and consistent placing every time
- Hydraulic motor powers a large durable chain that powers the mixing tub
- Unit comes complete with adjustable legs for storage and transport
- Main shaft is serviceable with a grease nipple
- Heavy Duty construction and a durable black paint finish

SIDE VIEW

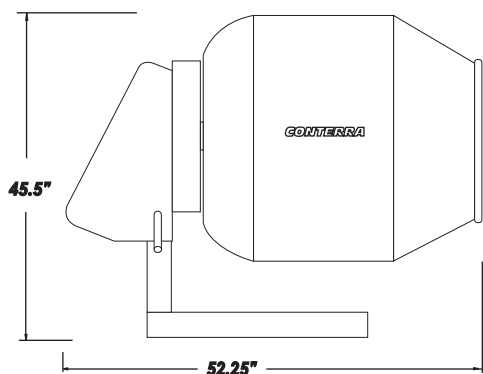

This product features our Grid Lock manufacturing technique that allows for increased strength with less overall weight.

SPECIFICATIONS:

Part #	Model #	Mixing Capacity	Drum Capacity	Drum Diameter	Drum Opening Diameter	Hydraulic Flow	Weight
500873	CM 5	5 cu. ft	9 cu.ft	36"	20"	8 GPM	436 lbs.

* The above numbers reflect the capacity of the attachment, not the skid steer. Please refer to your owners manual of your skid steer for lift capacities and hydraulic flow capabilities.



All products are subject to change without notice or liability.

Toll Free: 1-877-947-2882
www.conterraindustries.com

Box 59, Rockyford, Alberta Canada T0J 2R0
 Ph: (403) 947-2882 Fax: (403) 947-2892

G1