



BACKHOE



ES 640 for Mini Skid Steer Loaders

FEATURES:

- Mounts easily to any skid steer
- Ideal for fast and efficient excavating and trenching
- This curved boom design can reach into the hard to reach places for excellent digging performance
- Requires a hydraulic system of 5-7 GPM
- Dual-cylinder swing provides maximum swinging power
- Fold down legs provide excellent digging stability
- Available with optional tie back kit
- All main pivot greasable for easy maintenance
- Full width replaceable bronze bushings on all wearable pivot joints
- Boom & rotation lock for safe easy transport
- Buckets are built using AR 400 steel for long lasting performance
- 9", 12" buckets have 3 teeth, 15", 18" buckets have 4 teeth, 24" buckets has 5 teeth
- 24" smooth buckets are also available
- Available with optional street pads



Excavator designed boom allows for closer retraction of the bucket to the boom arm.

Heavy-duty buckets are made of AR 400 steel and available in widths of 9", 12", 15", 18", 24"

OPTIONS:

- Tie Back Kit



Easily accessible, ergonomically designed control station.



Dual cylinders allow for smooth, strong, consistent movement throughout the entire 180 degree swing range.



Cushioned swing cylinder dampens the swing at the end of the stroke, preventing unnecessary banging of the boom arm. This allows for smooth operation.



The stabilizers widen the center of gravity, making the narrow profile of your skid steer more sturdy when swinging the boom laterally.



All products are subject to change without notice or liability.

Toll Free: 1-877-947-2882
www.conterraindustries.com

Box 59, Rockyford, Alberta Canada T0J 2R0
Ph: (403) 947-2882 Fax: (403) 947-2892

E4

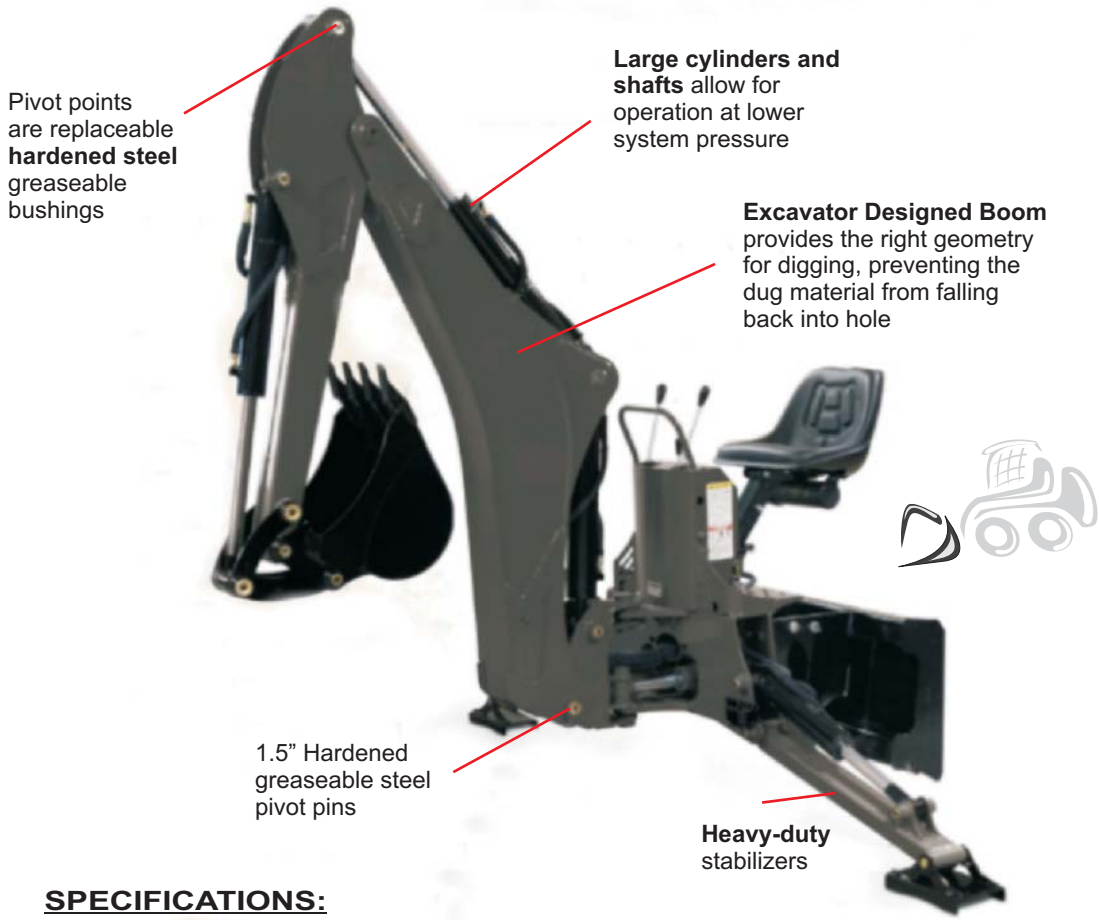

Pivot points are replaceable **hardened steel** greaseable bushings

Large cylinders and shafts allow for operation at lower system pressure

Excavator Designed Boom provides the right geometry for digging, preventing the dug material from falling back into hole

1.5" Hardened greaseable steel pivot pins

Heavy-duty stabilizers

SPECIFICATIONS:

<u>Model</u>	<u>Extension Length</u>	<u>Bucket Width</u>	<u>Bucket Dig Force</u>	<u>Weight</u>
BH 640-9T	68"	9"	2600lbs	675lbs
BH 640-12T	68"	12"	2600lbs	695lbs
BH 640-15T	68"	15"	2600lbs	710lbs
BH 640-18T	68"	18"	2600lbs	745lbs
BH 640-24T	68"	24"	2600lbs	790lbs
BH 640-24DB	68"	24"	2600lbs	785lbs
BH 940-9T	81"	9"	3925lbs	891lbs
BH 940-12T	81"	12"	3925lbs	911lbs
BH 940-15T	81"	15"	3925lbs	926lbs
BH 940-18T	81"	18"	3925lbs	961lbs
BH 940-24T	81"	24"	3925lbs	1,106lbs
BH 940-24DB	81"	24"	3925lbs	1,106lbs

* The above numbers reflect the weight of the attachment, and may be in excess of the lift capacity of some skid steers. Please check your owners manual for specific lift capacities.



All products are subject to change without notice or liability.

Toll Free: 1-877-947-2882
www.conterraindustries.com

Box 59, Rockyford, Alberta Canada T0J 2R0
 Ph: (403) 947-2882 Fax: (403) 947-2892

E5