



AUGER PLANETARY DRIVE



FEATURES:

- Built for skid steers
- Heavy duty planetary drive unit with 2" hexagon output shaft
- Unit comes complete with skid steer mount plate
- Standard augers from 6" to 36" diameter
- Tree augers from 18" to 36" diameter
- Planetary drive is completely sealed, with all moving parts running in oil for great lubrication.
- All gear design extends unit life and dramatically reduces maintenance
- Reverse rotation allows for quick back out and debris cleaning
- Swiveling Auger Head is self-plumbing for straight holes on uneven terrain
- Heavy Duty construction and a durable black paint finish

SPECIFICATIONS:

Model #	Drive Type	Torque 3000 to 4000psi	Output Speed as per flow GPM	Flow Required	Max Auger Diameter	Weight
ACD 6/15-2H	Chain	653 to 980 ft. lbs.	56 to 141 RPM	6 to 15 GPM	18"	415 lbs
ACD 10/20-2H	Chain	1,150 to 1,724 ft. lbs.	52 to 106 RPM	10 to 20 GPM	36"	418 lbs
APD 10/20-2H	Planetary	1,206 to 1,807 ft.lbs	51 to 102 RPM	10 - 20 GPM	18"	420 lbs
APD 15/30-2H	Planetary	1,731 to 2,597 ft.lbs	52 to 103 RPM	15 - 30 GPM	36"	440 lbs
APD 15/42-2H	Planetary	1,380 to 2,760 ft.lbs	60 to 159 RPM	15 - 42 GPM	36"	460 lbs

** The above numbers reflect the capacity of the attachment, not the skid steer. Please refer to your owners manual of your skid steer for lift capacities and hydraulic flow capabilities.

SIDE VIEW

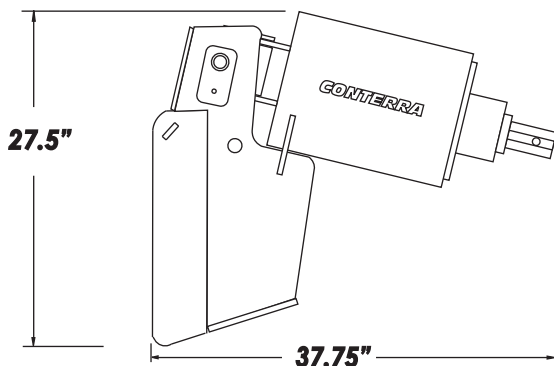

GRID LOCK
Manufacturing Technique

This product features our Grid Lock manufacturing technique that allows for increased strength with less overall weight.



All products are subject to change without notice or liability.

Toll Free: 1-877-947-2882
www.conterraindustries.com

Box 59, Rockyford, Alberta Canada T0J 2R0
Ph: (403) 947-2882 Fax: (403) 947-2892

E1